

LINEAR ACTUATORS

CTP linear Actuators feature:

- ✓ Die-cast aluminum power heads available in several gear ratios able to handle loads up to 4000 lbs.
- ✓ Motor voltages include 12, 24, 36 Volt DC or 110 and 220 volt AC.
- ✓ Acme and ball screws are available.
- ✓ Dynamic load capacity of 3000 lbs.
- ✓ Static load capacity 5000 lbs.
- ✓ Temperature Range: 90°C, 194°F Maximum to -35°C, -30°F Minimum.

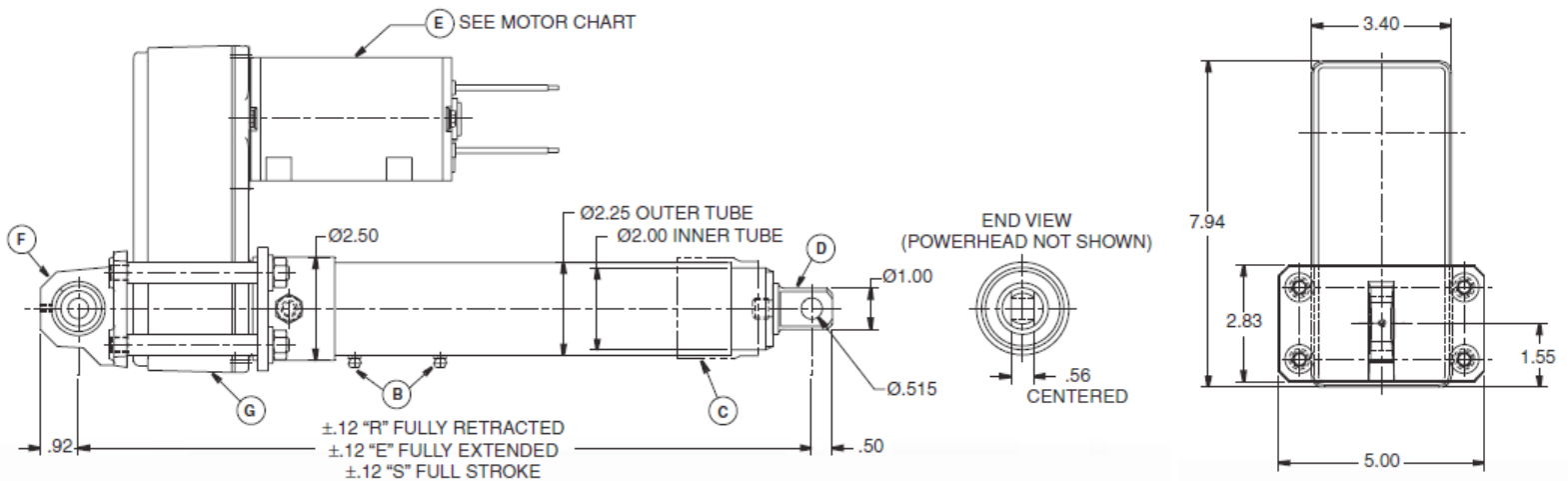

* Other part no. not included in the list are available. Please contact your sales representative if you have any questions. Part Numbers are used for reference purposes only.

Linear Actuators

Part No.	Description	Application
4793060	ACTUATOR GP-POWER	950H, 962H, 966H, 972H,
4793070	ACTUATOR AS	980C

Linear Actuator Parts:

Part No.	Description	Application
2624918	POWERHEAD AS	824G, 825G, 826G, 938G, 938G II, 950G, 950G II, 962G, 962G II, 966G, 966G II, 966H, 972G, 972G II, 972H, 980G, 980G II, IT38G, IT62G, IT62G II
1171559	MOUNT AS	50, 550B, 560B, 570, 570B, 580, 580B, 725, 730, 824G, 825G, 826G, 938G, 938G II, 938H, 950G, 950G II, 950H, 962G, 962G II, 962H, 966G, 966G II, 966H, 972G, 972G II, 972H, 980G, 980G II, CS-531D
1224233	WIPER	10 FT, 10B, 550, 550B, 560B, 570, 570B, 580, 580B, 725, 730, 8 FT, 824G, 825G, 826G, 938G, 938G II, 938H, 950G, 950G II, 950H, 950K, 962G, 962G II, 962H, 962K, 966G, 966G II, 966H, 966K, 966M, 966M XE
1682166	GASKET-MOTOR	10 FT, 10-20B, 10B, 550, 550B, 560B, 570, 570B, 580, 580B, 8 FT, 8-16B, 824G, 825G, 826G, 938G, 938G II, 938H, 950G, 950G II, 950H, 950K, 962G, 962G II, 962H, 962K, 966G, 966G II, 966H, 966K, 966M
2036470	GASKET KIT	550, 550B, 560B, 570, 570B, 580, 580B, 824G, 825G, 826G, 938G, 938G II, 950G, 950G II, 962G, 962G II, 966G, 966G II, 966H, 972G, 972G II, 972H, 980G, 980G II, IT38G, IT38G II, IT62G, IT62G II
2036473	GASKET	550, 550B, 560B, 570, 570B, 580, 580B, 725, 730, 824G, 825G, 826G, 938G, 938G II, 938H, 950G, 950G II, 950H, 950K, 962G, 962G II, 962H, 962K, 966G, 966G II, 966H, 966K, 966M, 966M XE, 972G, 972G II
2056029	MOTOR AS-ELECTRIC	550, 550B, 560B, 570, 570B, 580, 580B, 824G, 825G, 938G, 938G II, 938H, 950G, 950G II, 950H, 962G, 962G II, 962H, 966G, 966G II, 966H, 972G, 972G II, 972H, 980G, 980G II, IT38G, IT38G II, IT38H, IT62G
2126854	ROD END	550, 550B, 560B, 570, 570B, 580, 580B, 725, 730, 824G, 825G, 826G, 938G, 938G II, 950G, 950G II, 962G, 962G II, 966G, 966G II, 966H, 972G, 972G II, 972H, 980G, 980G II, CS-531D, CS-563D, CS-573D, CS-5
2780644	GASKET-COVER	10 FT, 10-20B, 10B, 8 FT, 8-16B, 938G II, 938H, 950H, 950K, 962H, 962K, 966H, 966K, 972H, 972K, AP-1055D, AP-600D, AP-655D, AP-800C, AS2251, AS2252C, AS2301, AS2302, AS2302C, AS3251C, AS3301C, AS4252C
3058966	POWERHEAD AS	938G II, 938H, 950H, 962H, 966H, 972H, IT38G II, IT38H, IT62H
3058969	POST AS	938G II, 938H, 950H, 962H, 966H, 972H, IT38G II, IT38H, IT62H
3082071	ROD END	938G II, 938H, 950H, 950K, 962H, 962K, 966H, 966K, 972H, 972K, IT38G II, IT38H, IT62H
1682166	GASKET-MOTOR	10 FT, 10-20B, 10B, 550, 550B, 560B, 570, 570B, 580, 580B, 8 FT, 8-16B, 824G, 825G, 826G, 938G, 938G II, 938H, 950G, 950G II, 950H, 950K, 962G, 962G II, 962H, 962K, 966G, 966G II, 966H, 966K, 966M

* Other part no. not included in the list are available. Please contact your sales representative if you have any questions. Part Numbers are used for reference purposes only.